

Understanding Transportation Management Systems Performance with a Simulation-Based Learning Environment

Catherine Plaisant, Phil Tarnoff^{#}, Sumeet Keswani*, Aditya Saraf*, Anne Rose,*

Human-Computer Interaction Laboratory,
University of Maryland Institute for Advanced Computer Studies
<http://www.cs.umd.edu/hcil>

[#]Center for Advanced Transportation Technology
^{*}Institute for Systems Research

University of Maryland, College Park, MD 20742

plaisant@cs.umd.edu tarnoff@eng.umd.edu
(301) 405-2768 (301) 405-3103

ABSTRACT

We have developed a simulation-based learning environment to provide system designers and operators with an appreciation of the impact of incidents on traffic delay. We used an application framework developed at the University of Maryland for constructing simulation-based learning environments called SimPLE (Simulated Processes in a Learning Environment). Environments developed with SimPLE use dynamic simulations and visualizations to represent realistic time-dependent behavior and are coupled with guidance material and other software aids that facilitate learning. The simulation allows learners to close freeway lanes and divert traffic to an arterial road. Users can see the effect of the detour on freeway and arterial delay. Users can then adjust signal timing interactively on a time space diagram and watch the effect of their adjustment on green band changes and on arterial delays and total delays.

KEYWORDS: transportation management systems, simulation, education, learning environments, signal timing, arterial delays, freeway delays

INTRODUCTION

Advanced transportation management systems (ATMS) are being installed throughout the United States in an effort to reduce the impact of incidents on freeway traffic flow. Since freeway incidents account for approximately 50% of the delay experienced on the nation's highway system, these systems potentially offer a significant opportunity for reducing their impact.

The majority of ATMS are designed to:

- Reduce incident response times
- Coordinate incident response activities
- Notify motorists of the presence of an incident

While these existing functions are performed very effectively by ATMS, there is an additional function that offers the potential for even greater reduction of delays during incidents – traffic management. Currently motorists receive incident notification through variable message signs (VMS), traveler's advisory radio (TAR) or commercial radio. Public agencies responsible for the operation of the VMS and TAR, are reluctant to provide supplementary diversionary recommendations along with the incident notification information. Instead, diversionary recommendations are provided by commercial radio broadcasters, relying on information received from aerial observations. Public agencies are hesitant to provide such information because of inadequate information about traffic conditions on alternate routes as well as a fear that too many motorists will divert to the recommended alternate route, resulting in an imbalance in traffic demand. They are also limited by the absence of definitive information regarding motorists response to various types of sign messages. It would be important to know how many motorists are likely to divert when a specific message is posted. Yet balancing traffic demand as well as the adjustments of signal timing on parallel arterials, represents an opportunity for significant increases in the effectiveness of many of today's ATMS system.

In addition, ATMS technology has not significantly expanded into coordinated control of freeways with displays of diversionary information, and signalized arterials with signal timing adjusted to accommodate the surge of incident related traffic, for the following reasons:

1. ATMS operators are rarely trained in the principals of signal timing. This is a complex subject, which requires hands-on experience to develop an adequate appreciation of its use.
2. Incident related signal plans are not always available.
3. It is difficult to predict the percent of traffic that will divert from a freeway to a parallel arterial, since this represents the complex interaction of the VMS/TAR message, percent of familiar drivers, percent of commercial traffic, and characteristics of the incident.
4. Signals may be operated by a local agency rather than the state.

Thus, effective corridor control is a complex operational challenge. Yet the potential benefits of such control are adequate to justify the development of improved graphics and training tools. It is anticipated that the work described in this paper represents the first steps toward the development of new, more effective training and operational capabilities.

The objective of this project was to develop an educational environment that would provide a better appreciation of the benefits of traffic management and traffic diversion during incidents. It was also intended to provide a better understanding of the rudiments of signal timing, so that the impact of signal adjustments under varying traffic conditions would be appreciated. This tool is designed for system managers, engineers and operators. It could also be used to demonstrate the benefits of coordinated control of freeways and signalized arterials by multiple agencies.

The SimPLE environment (Simulated Processes in a Learning Environment) on which this development is based [Lu et al., 96] [Rose et al, 98], can be integrated into existing training and educational programs or adapted for stand-alone training in incident management. Modules developed with SimPLE can be used without any prior training. It offers a stand-alone active learning educational environment with supporting text, diagrams and animations. Thus it can also be a form of distance learning since it can be delivered without requiring a formal classroom setting. It can be installed and executed on ordinary personal computers.

THE CASE FOR SIMULATION ENVIRONMENTS

Simulation environments are powerful learning tools that encourage exploration by allowing learners to manipulate parameters and visualize results [Nahvi, 96][Woolf and Hall, 95]. In academic settings, they are used to enhance lectures, supplement labs, and engage students. In the workplace, they are cost-effective training mechanisms. There are two basic groups of simulators: inanimate (off-line) and live (on-line, real-time). Inanimate simulators are used to evaluate complex equations and models. They do not simulate real-time operations of physical systems so user interaction is limited. However, live simulators are highly interactive. They closely resemble the physical system while allowing learners to explore situations not possible with the actual system.

SimPLE is an application framework for constructing live simulation-based learning environments. It pairs the power and flexibility of a generic simulation package with the advantage of a custom front end. Learning environments developed with SimPLE use dynamic simulations and visualizations to represent realistic time-dependent behavior and are coupled with guidance material and other software aids that facilitate learning. The software architecture enables independent contributions from developers representing educational content (e.g., simulation models, guidance materials) and software development (e.g., user interface) to be assembled easily. This allows the educational content (e.g., simulation models and guidance materials) to be developed by the educators who have the domain knowledge. Using the user interface template

provided and several software aids, SimPLE allows custom front ends to be created quickly and with minimal coding. Three learning environments have already been created for other application domains: ClusterSim and VacTechSim for learning about semiconductor manufacturing, and NileSim for learning about the hydrology of the Nile (<http://www.isr.umd.edu/SimPLE/>).

This paper describes the new module now being developed to train ATMS operators and managers on traffic performance issues.

DESCRIPTION OF THE USER INTERFACE

Harnessing the benefits of direct manipulation

To improve the learnability and usability of the simulation, attention was given to careful user interface design [Shneiderman, 97]. A visual, interactive design was chosen, applying the principles of direct manipulation [Shneiderman, 83]. Direct manipulation relies on:

1. Continuous representation of the objects and actions of interest
2. Physical actions or presses of labeled buttons instead of complex syntax
3. Rapid incremental reversible operations whose effect on the object of interest is immediately visible

Using these three principles, it is possible to design systems that have these beneficial attributes:

- Novices can learn basic functionality quickly, usually through a demonstration by a more experienced user.
- Experts can work rapidly to carry out a wide range of tasks, even defining new functions and features.
- Knowledgeable intermittent users can retain operational concepts.
- Error messages are rarely needed.

Overall description of the interface

The interface consists of 3 main areas as shown in Figure 1 (corresponding to initial state of the simulation.) The top part of the screen is the main simulation area, showing both input controls (i.e. volume control and lane closing controls) and output displays (i.e. a delay chart showing delays over time). The bottom part is the guidance material area where students can read about traffic performance, find exercises and explanations of the observed “behavior” of the simulation. The smaller middle area contains the simulation controls (e.g. start, stop, continue).

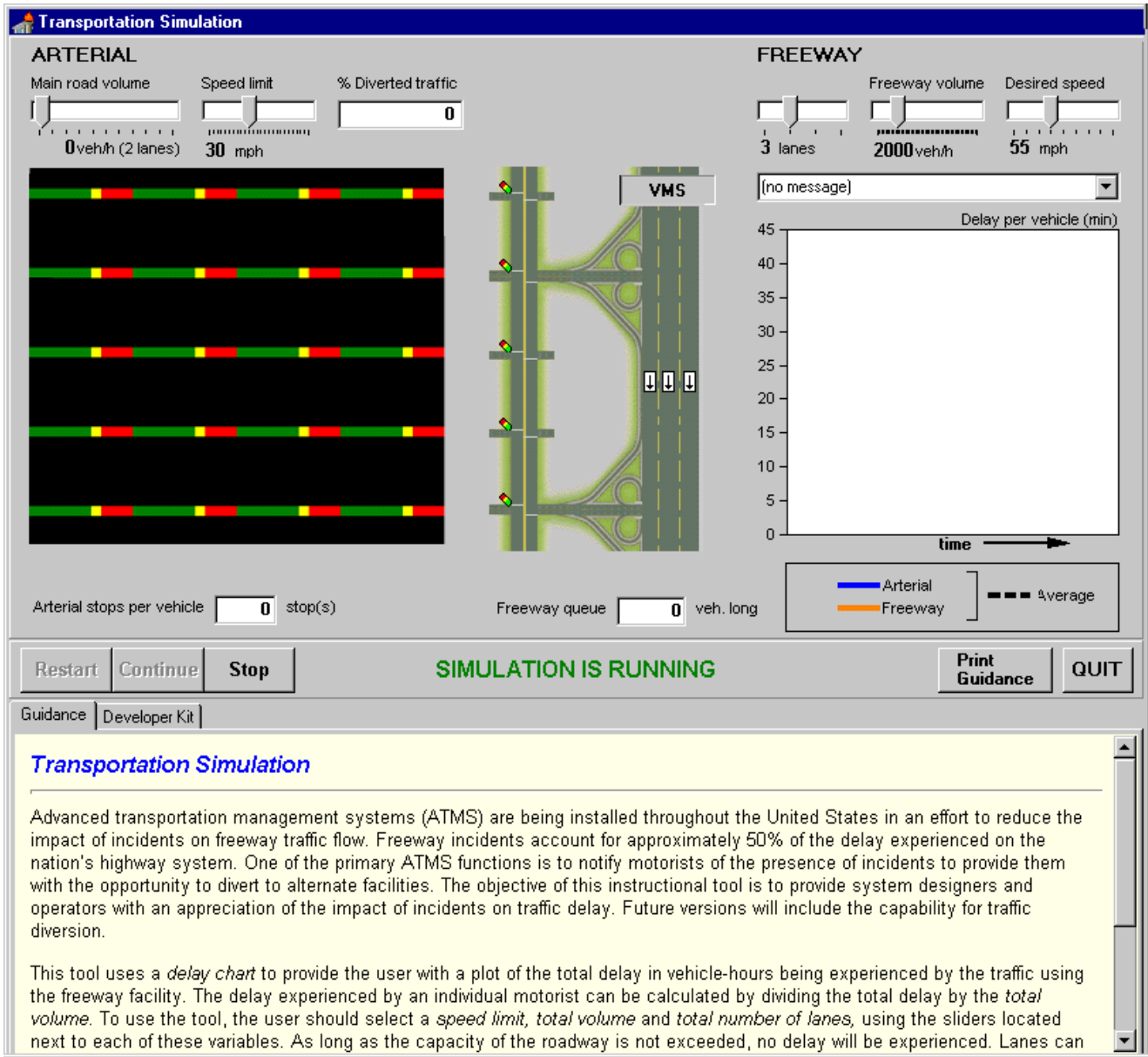

Figure 1: At the start of the simulation: can chose volumes, speed limits and number of freeway lanes. All freeway lanes are clear and there is no message on the Variable Message Sign. The delay chart on the right shows no delay. The screen is divided three areas: the simulation main area (top), the simulation controls (middle) and the guidance materials (bottom). Users can click on the terms highlighted in the guidance materials (e.g., delay chart) and the location of the corresponding object is temporarily highlighted on the simulation display.

Three aspects of traffic performance can be explored with the simulation. The effect of volume and lane closing on freeway delays, the effect of signal timing on arterial traffic, and the combined effect of lane closing and diversions on arterial and freeway traffic.

Effect of volume and lane closing on freeway delays

When starting the simulation users can adjust the speed limit, total volume and number of lanes, using the sliders located next to each of these variables. As long as the capacity of the freeway is not exceeded, no delay will be experienced. Lanes can be closed on the highway by clicking on the boxes in each lane, in order to simulate incidents (instead of an arrow the lane shows a red X). The delays will then increase on the delay chart. The incident can be eliminated or reduced in severity by opening lanes on the freeway.

Effect of signal timing on arterial traffic

At the start of the simulation, users can also study as a separate exercise the effect of traffic volume and speed limit on the arterial traffic. The time-space diagram shows the signal timing of a series of intersections (here 5). The X axis represents time in seconds and the Y axis is distance. For each intersection the colored line shows the signal timing as a succession of green, yellow and red time periods. Users can adjust the offset of each intersection (by clicking on a green or red band and sliding the entire line right or left), or adjust the green time ratio (by clicking on a transition time e.g., red to green, and sliding it to the desired place). As users slide part of the diagram the green bands are recalculated interactively and displayed in real time (i.e. less than 100ms.). The meaning and “behavior” of the time-space diagram is explained in the guidance materials. Simple exercises are proposed to gain familiarity with this complex diagram.

Combined effect of lane closing and diversions on arterial and freeway traffic.

Finally, users also have the capability to divert traffic onto parallel signalized arterial roadways. By changing the message used on the highway (i.e. on the Variable Message Sign or VMS) users can alter the percent traffic being diverted. This value is shown in percentage diverted traffic box (top center part of the display).

The objective is to provide an appreciation of the benefits of providing diversionary information to motorists, and experience with the adjustment of signal timing.

A scenario might be as follow: (Note: Quantitative values should be seen as VERY approximate at this point of development of the simulation)

1. The simulation is started by clicking on the Start button. Users select values for the freeway and arterial volumes, speeds, and number of freeway lanes.
2. All freeway lanes are clear, there is no message on the Variable Message Sign. The arterial flow is under capacity, and the green band does not use the available green time. The plot on the right shows no delay. The percentage of diverted traffic is 0% (Figure 1)
3. Closing two freeway lanes simulates an incident (by clicking on the arrows drawn on the lanes.)
4. The freeway delay is rapidly increasing, the queue is up to 93 vehicles on the freeway. The delay chart shows that the average freeway delay raised to 15 minutes. There is still no VMS message, no diverted traffic, the arterial conditions are unchanged (Figure 2.)

5. Traffic is being diverted by displaying a “Accident ahead” message on the Variable Message Sign. It should be emphasized that the assumed percent of diverted traffic in response to this sign message is “contrived”. Adequate data relating diversion to sign messages is not currently available.
6. The freeway delay decreases to 10-minute average and a queue of 70 vehicles. But 15% of diverted traffic cause problems in the arterial. The flow is over capacity, the green band uses all the green time, leading to an average of 1.8 stop per vehicle for the main road section of the detour. The delay increases to 5-minute for the main road and 3-minute average for the diverted traffic (Figure 3.)
7. The signal timing of the lower intersections (3rd, 4th and 5th from the top) is adjusted by changing their offset (i.e. sliding the entire line), and by increasing the green time at third intersection from the top (also by direct manipulation on the line.) The calculation of delays will take into account side street delays resulting from increased green time on the arterials, to eliminate the obvious solution of providing the arterial with the maximum allowable green time independently from side street performance.
8. The arterial delays are reduced and the overall average delay as well (Figure 4.)

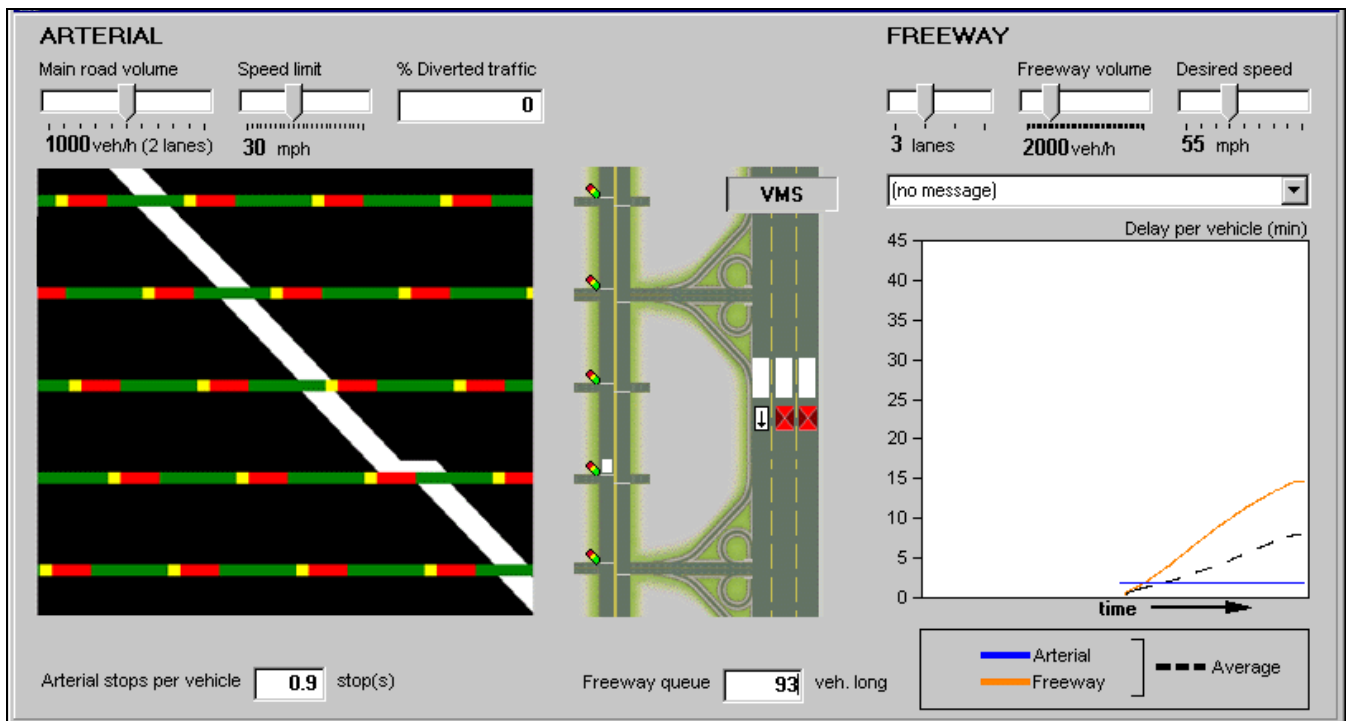

Figure 2: The arterial flow is under capacity, and the green band does not use the available green time. Two freeway lanes are now closed and the delay chart shows that the freeway delay rapidly increased to 15 minutes per vehicle while arterial conditions remained the same. (NOTE: all quantitative values are approximate in this early prototype)

[additional black and white figures at the end of the document]

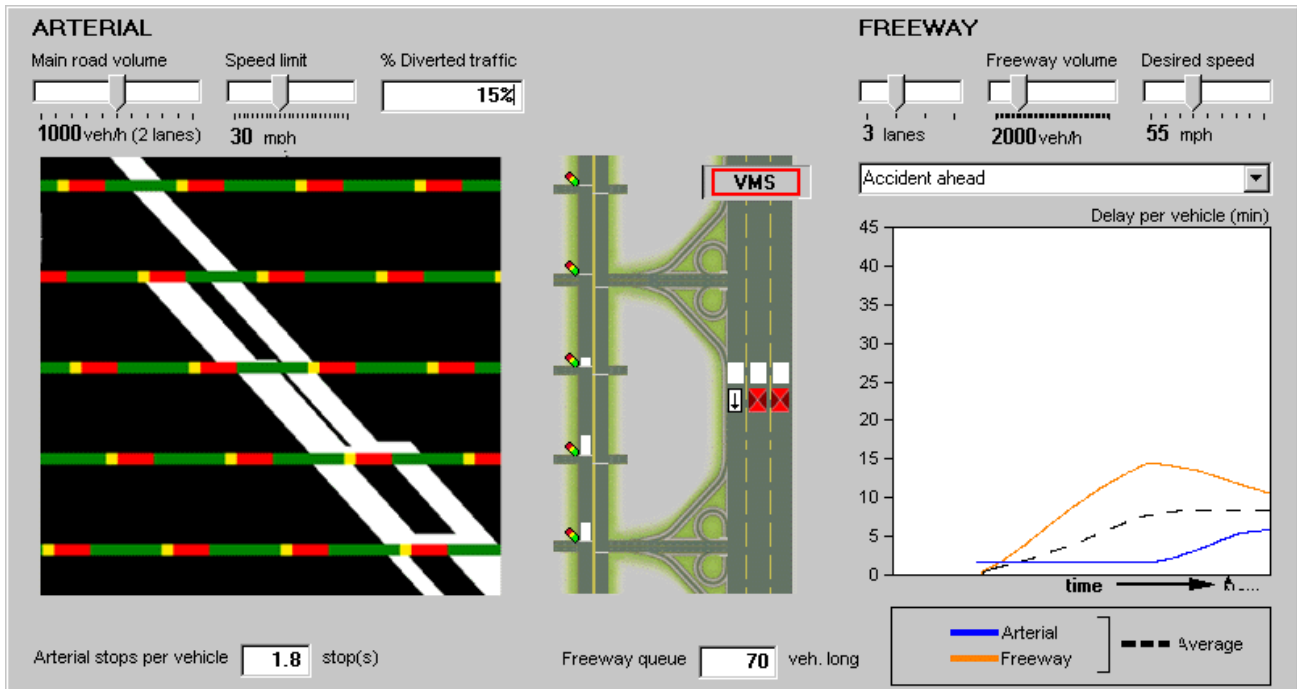

Figure 3: A message is posted on the freeway message sign, diverting 15% of the traffic onto the arterial. The freeway delays decreased but the arterial became congested. The diverted traffic enters the main road during the red time of the second intersection from the top, vehicles queue behind the lights, and slows the main roadway traffic. At the fourth intersection the diverted traffic returns to the freeway and the traffic returns to normal.

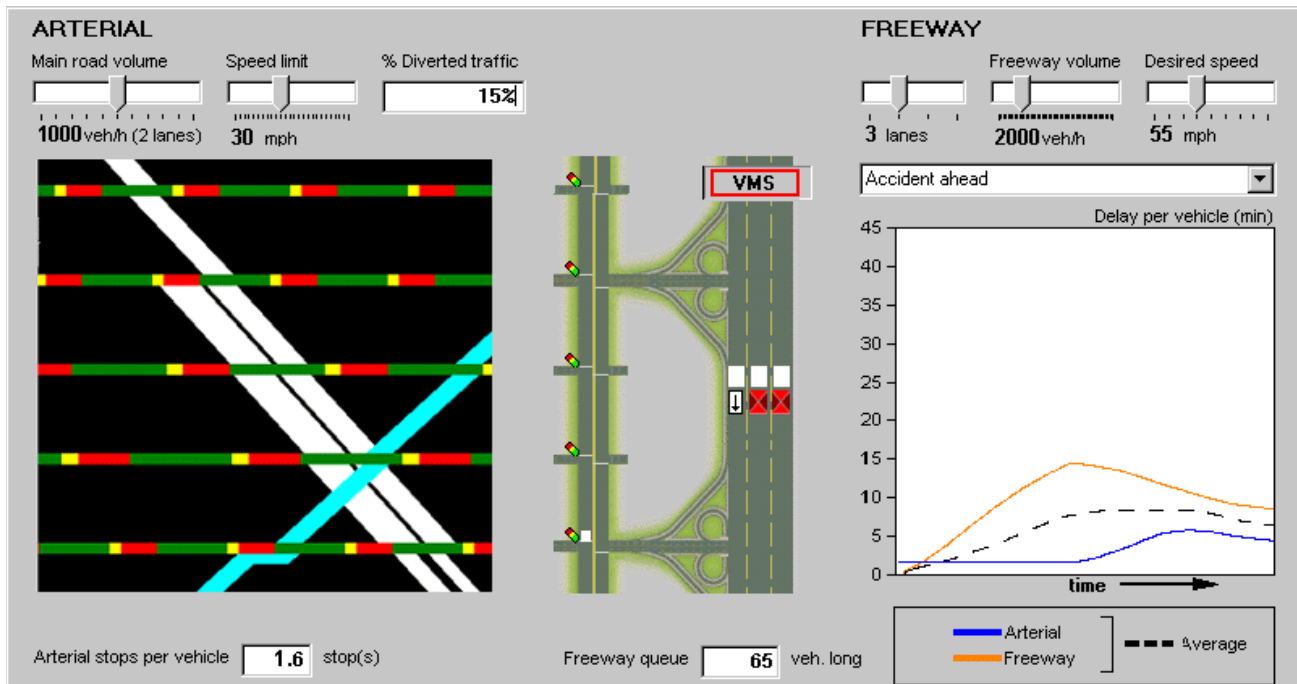

Figure 4: The signal timing of the 3rd and 4th intersections from the top was adjusted. Fewer vehicles have to wait for a second cycle at the 3rd intersection. The arterial delays are reduced and the overall average delay as well. As users adjust the signal timing interactively on the time-space diagram, the effect on the bands is shown immediately and users can quickly explore alternatives. Users can then start checking the effect of the changes on the reverse direction traffic.

SYSTEM DESCRIPTION

The SimPLE environment developed at the University of Maryland facilitates the construction of simulation based environment by facilitating the integration of independent contributions from developers representing educational content or software development (Figure 5). Educational content include simulation models (Figure 6) or guidance materials (Figure 1), while software development includes the user interface of interactive components such as the time space diagram or the delay chart. SimPLE provides user interface templates and accompanying software aids to reduce the software development effort.

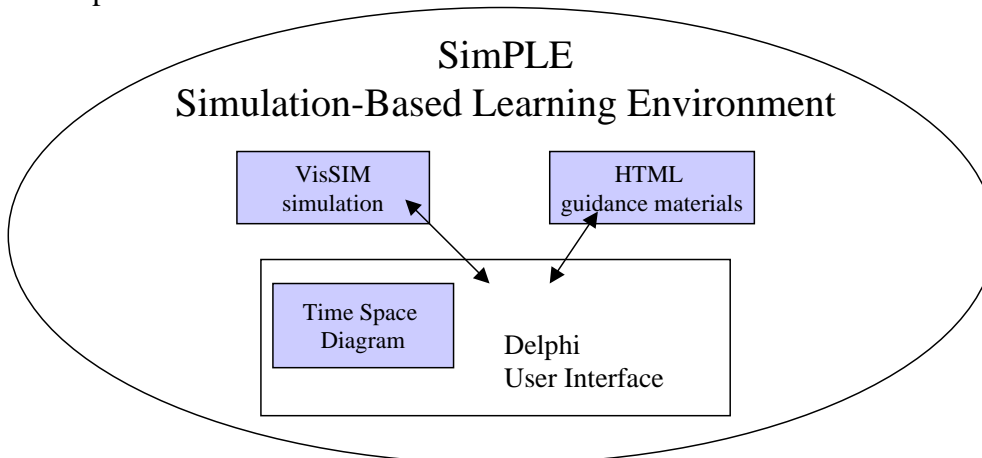

Figure 5: The SimPLE environment developed at the University of Maryland facilitates the construction of simulation based environment by facilitating the integration of different contributors.

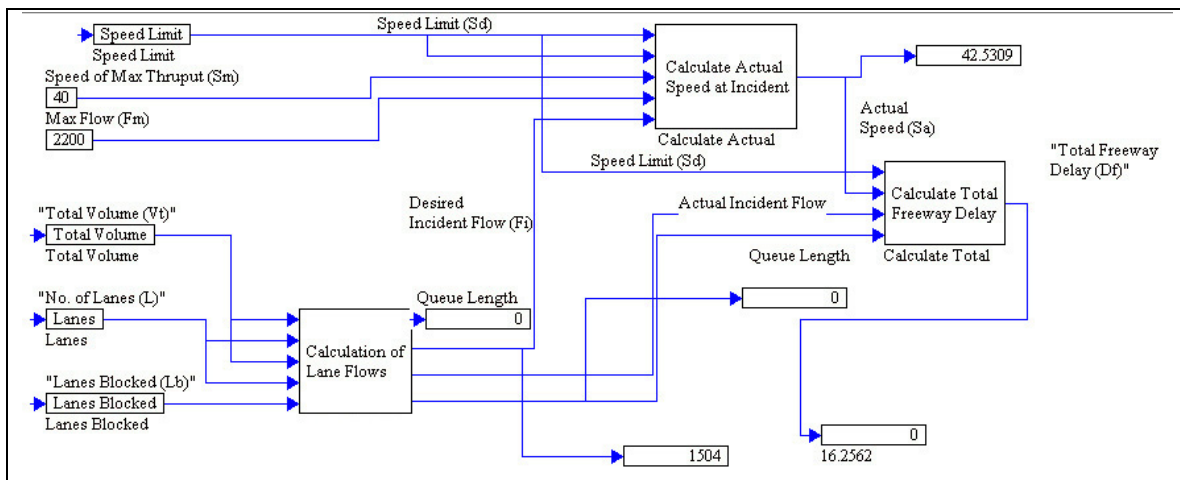

Figure 6: Sample of the VisSIM simulation showing freeway delay calculation.

CONCLUSIONS

SimPLE represents a new paradigm in technical instruction. It eliminates many of the shortcomings of traditional short-courses and other forms of classroom education [e.g.

see the [Intelligent Transport Systems Professional Capacity Building Program Course Catalog]). It provides a user-friendly environment that permits learning to occur without requiring prior training in the use of the applications software.

In the case of the traffic simulation described in this paper, the power of SimPLE has been applied to a complex problem that includes freeway and arterial management. It provides the user with an appreciation of the effects of lane closures, VMS messages, and signal timing. Independently these control actions are relatively simple. However, in combination they can have a complex and unpredictable results.

Equally exciting is the long term potential of this project. Activities are underway to couple SimPLE with the Federal Highway Administration's CORSIM program. This program will provide a more realistic simulation model of the impacts of the operator's actions. As a result of its accuracy, SimPLE and CORSIM will be used together to provide ATMS operators with a decision management tool that can provide them with rapid graphical feedback regarding the impact of their control decisions. In this way, operators can rapidly evaluate a range of different strategies that are being considered for traffic management during a major incident.

Acknowledgements

This work is supported by the National Science Foundation, under grant EEC 96-96212, and by the Maryland Department of Transportation.

Endnotes

1. "Intelligent Transport Systems, Professional Capacity Building Catalog Course Catalog", U.S. Department of Transportation, Washington, DC
2. Lu, G. B., Oveissi, M., Eckard, D., and Rubloff, G. (1996). "Education in semiconductor manufacturing processes through physically-based dynamic simulation". Proceedings of Frontiers in Education '96, IEEE, 250-253.
3. Nahvi, M. (1996). "Dynamics of student-computer interaction in a simulation environment: Reflections on curricular issues". Proceedings of Frontiers in Education '96, IEEE, 1383-1386.
4. Rose, A., Eckard, D. and Rubloff, G., "An Application Framework for Creating Simulation-Based Learning Environments", University of Maryland Technical Report CS-TR-3907, College Park, MD 20782.
5. Shneiderman, B., "Direct manipulation: A step beyond programming languages", IEEE Computer 16, 8 (1983), 57-69.
6. Shneiderman, B., "Designing the User Interface: Strategies for Effective Human-Computer Interaction: Third Edition", Addison-Wesley Publishing Co., Reading, MA (1997).
7. Woolf, B. and Hall, W. (1995). "Multimedia pedagogues: Interactive systems for teaching and learning". IEEE Computer, May 1995, 74-80.

For more information see: <http://www.cs.umd.edu/hcil/highway>

Same figures for black and white printing

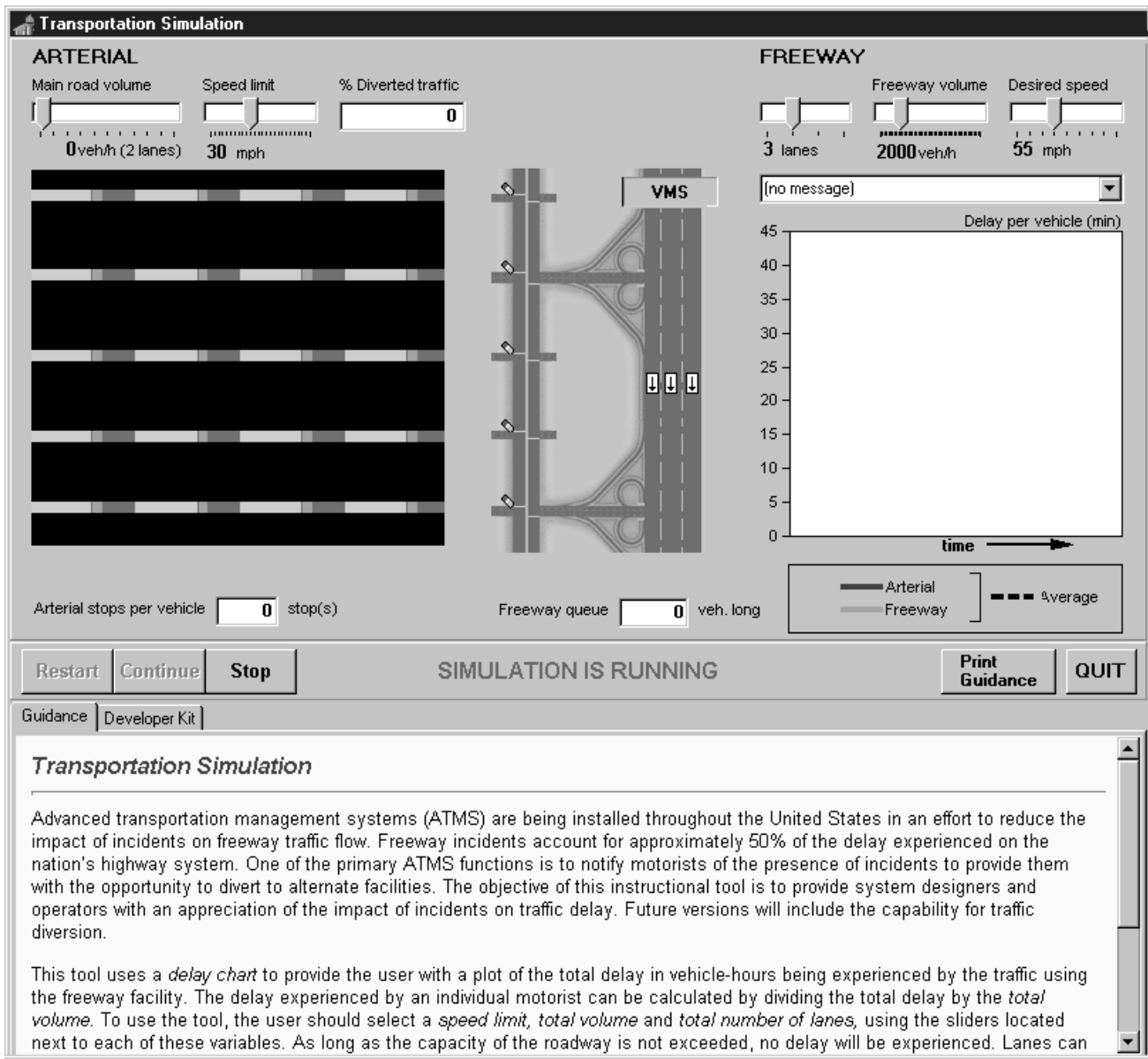

Figure 1

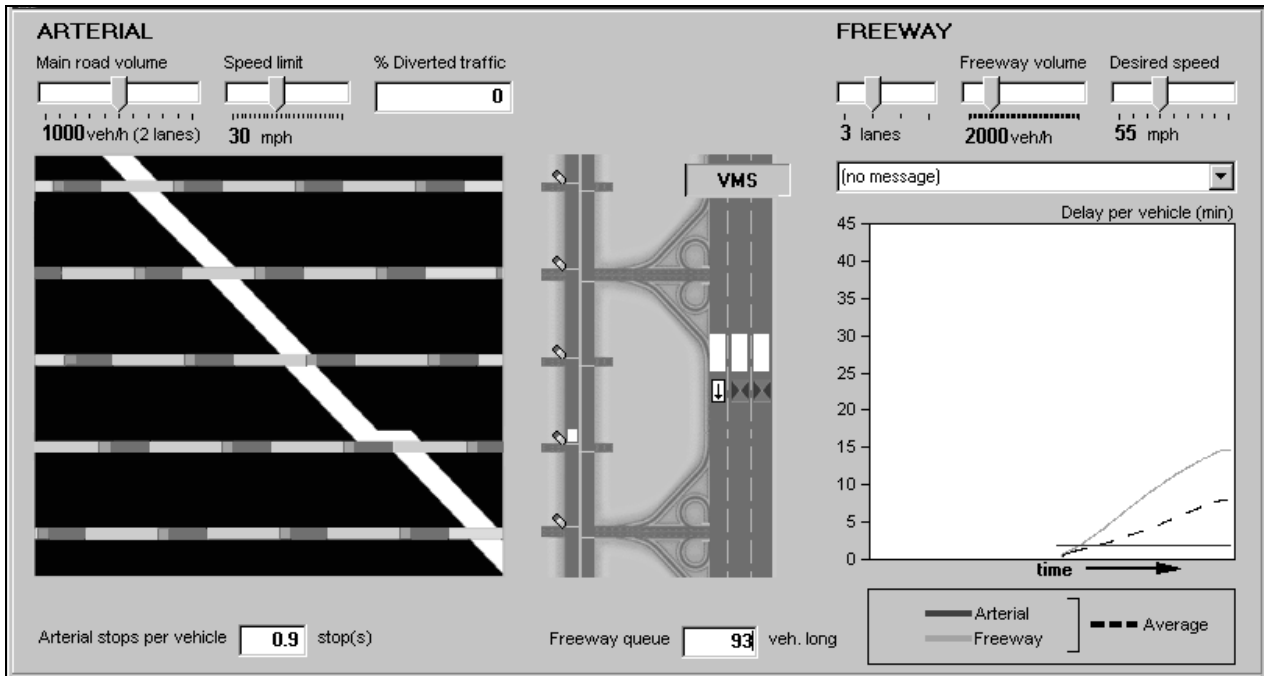

Figure 2

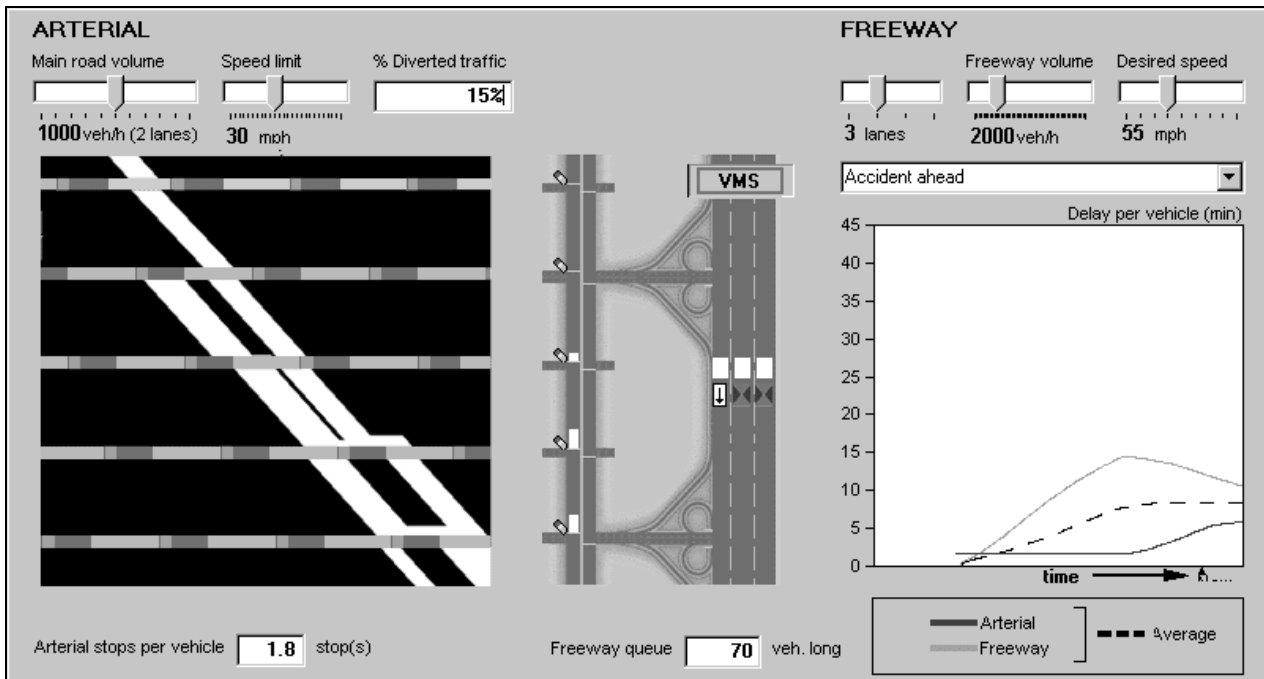

Figure 3

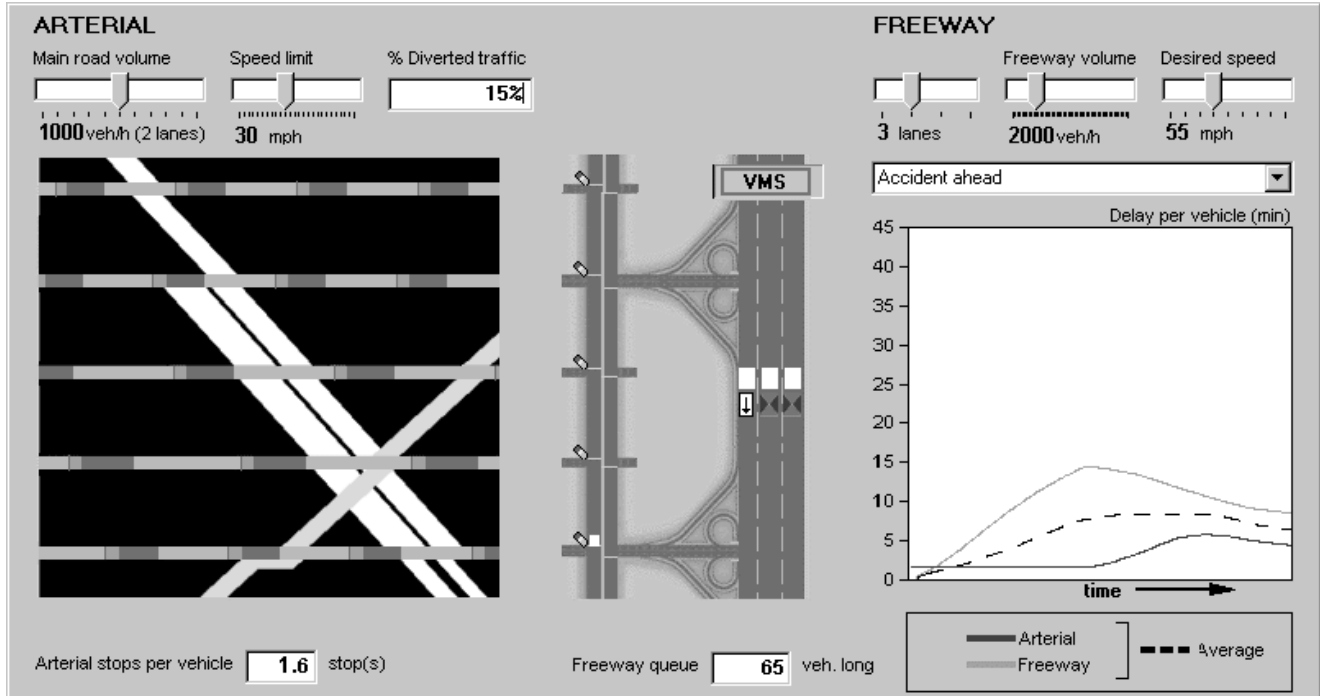

Figure 4